



INSTRUCTIONS MANUAL

Professional Electric Oven mod.

F1 - F1C - F11 - F11C

Release
01 - 2019



INTRODUCTION

READ CAREFULLY THE WHOLE MANUAL BEFORE UNPACKING AND INSTALLING THIS PRODUCT.

Dear Customer, thank you for choosing one of our quality products.

Our expert production follows the guiding principle of the strictest quality control of each component so as to guarantee that our products will function efficiently far into the future. The mechanical, electrical, and electronic parts were designed and manufactured to guarantee reliability and high-quality functioning.

The use of parts that are not original could cause functioning problems or damage to the product. Therefore, always ask for any spare parts from authorized dealers to return the product to perfect working order.

All the machines we manufacture are made using modern technology and systems of tested reliability. We systematically referred to the current standards and regulations for mechanical products, specifically the UNI standards and the CEI standards for electric and electronic equipment. The units that are described in this manual, like all our products, are manufactured according to criteria of good practice and in strict compliance with the European directives and related regulations.

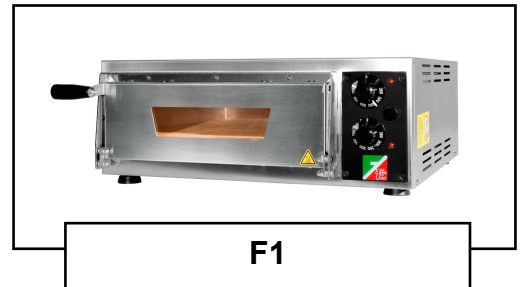

GENERAL USE PRECAUTIONS

Carefully read the warnings that are contained in the present instruction manual, as it supplies important indications concerning installation security, use and maintenance of the appliance. In this way you will avoid possible incidents which would compromise your security.

After having removed the packing, make sure that the appliance is in good order. If the power cable is damaged, it must be replaced by the manufacturer or its technical service assistant or however by a similar qualified person, so as to prevent every risk.

Before connecting your oven, verify that data on the plate are suitable with those of your electrical net. The appliance can endure damages in case of not suitable tension. In case of incompatibility between your socket and the oven plug, replace it with another adapted one, the replacement must be done by a professionally qualified staff. He will have also verify, in particular, that the cables section of the plug is suitable to the power absorbed by your oven.

In general, it is not suggested the use of adapters, multiple plugs and/or additional cable plugs. In case their use became indispensable, it is necessary to use only simple or multiple adapters and additional cable plugs allowed by the enforced security rules. Pay attention do not exceed the capacity limit of power supply value, marked on the simple adapter and on the additional cable plug. Do not exceed also the maximum power supply marked on the multiple adapter.

Do not use the appliance if it shows damages to the power cable or to the plug.

Do not use the appliance after an eventual anomalous functioning. In such case turn it off and not try to repair it. For the eventual repair address to a technical assistance center authorized by EffeUno requiring only original spare parts, otherwise the security of your appliance could be compromised.

This appliance will have to be destined only to the use for which it has been expressed conceived. Every other use is to be considered improper and therefore dangerous. The manufacturer cannot be considered responsible for eventual damages deriving from improper, erroneous and unreasonable uses. This appliance is exclusively destined to a professional use.

Do not dip for no reason the appliance, the cable, the plug or other oven parts in water or other liquids; it could cause electrical shocks!

Do not use the appliance in presence of explosives, strongly inflammable substances, ignited gas or flames.

Do not allow that the oven is used by children or incapables, without adapted surveillance. The oven must always work with the operator's control in order to ensure it is used in a proper way. Children must be supervised, to ensure that they don't play with the appliance.

Don't use the appliance at less than a 5m minimum distance from other machines like fryers or others, which oils, flours or similar substances can come out from.

Do not bring the appliance with bathed hands or feet.

Do not use for no reason accessories not previewed from EffeUno, they could cause serious danger.

Do not use the oven nearby the bathtub, shower or washbasin, or where the water presence can be a possible danger source.

Never pull the cable, or the appliance itself, in order to detach the plug from the net socket.

Do not leave the cable hanging.

Do not leave the appliance in places exposed to atmospheric agents as rain, wind, snow, hail etc. Not use it outside, not even under shed or cover.

Take out the plug from the electrical socket when the appliance is not used or during the cleaning of the same. Wait until the oven is cool before inserting or removing objects and before proceeding with the cleaning.

Do not introduce foods of excessive dimensions or metallic tools: it could cause fires or electrical shocks.

Pizza, bread or other foods can burn. The oven does not have to be used nearby curtains or other inflammable materials.

Leave a minimum 15-20 cm space around the oven, in order to let air go through at both left and right side, on the oven and behind it.

Do not put objects on the oven when it is in function. If the oven is covered or comes in touch with inflammable materials (including curtains, fabrics, walls and similar) during its functioning, it can develop flames.

Do not introduce in the oven material like cardboard, plastic, paper or similar because they are inflammable, alternatively introduce only those expressly adapted to high temperatures.

Do not keep any type of material inside the turned off oven.

The appliance is turned off only when the plug has been taken out from the electrical socket.

Warning! Place the oven in such way to easily open the door. Not place objects that could avoid the door movement.

Do not put cold water on the inner glass of the door when it is open, the glass could break off. Every thermal shocks have to be avoided.

Always wear cooking gloves with grip resistant to heat, while introducing or removing objects from the warm oven.

For the desk version we suggest the installation on a table or a horizontal plan at a height at least of 85 cm, out of children capacity. Moreover keep a distance of at least 15 cm between the oven and the furniture/walls around. As a support for the appliance, don't use materials different from stainless steel and/or marble.

NOT STOCKABLE NEITHER RECESSABLE EVEN IF PARTIALLY

BEFORE THE USE

It is a special electrical oven for pizza, studied and manufactured with baking plans made in refractory stone, allowed to the alimentary use. The main advantage of this material is that it gives uniform heat, absorbs the humidity of the dough during the baking, obtaining therefore the result to cook a crispy pizza at home with the same results of renowned pizzerias.

It cooks in approximately 4/5 minutes whichever type of pizza, Neapolitan pizza roll, etc using dough made at home or bought from the baker. It is



INSTRUCTIONS MANUAL

Professional Electric Oven mod.

F1 - F1C - F11 - F11C

Release
01 - 2019



possible to use any other type of dough or ready pizza (frozen, precooked, etc). In this last case the use of our pizza oven reduces the baking times indicates on the product confection. If you are using a n electrical socket nearby the equipment, pay attention that the appliance cables does not touch it and enough far from the warm parts of this equipment. The parts of this equipment are heated during the baking and remain warm for a certain period also after the turning off. Take care do not touch the heating elements inside the appliance. After to have used the equipment, be sure that all controls are in OFF position. While opening the oven door during the baking phase or at the baking end, pay attention to the warm air flow that comes out from the oven

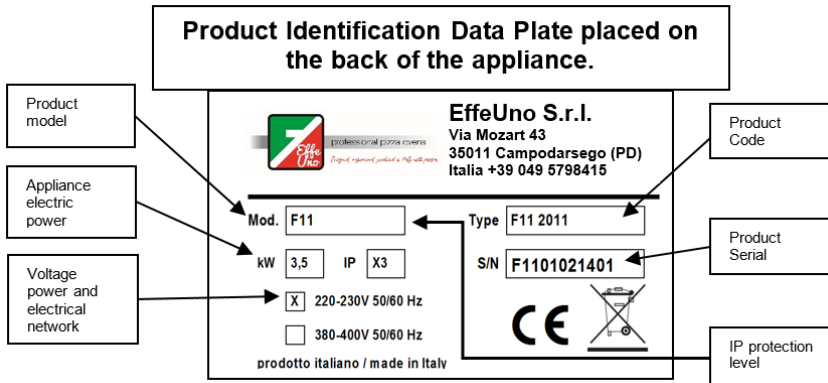

WARNING!!

In order to obtain a substantial and effective extension of the reliability of the regulation thermostat, we expressly suggest you to bring back the regulation index in position "zero" only when the oven is cold.

CONNECTION TO THE ELECTRICAL NET

The connection to the electrical net and set in motion of the appliance must be done by a qualified and experienced installer, following the technical rules and regulations of the Country of installation.

Prepare a line trunk near the equipment, so that the cable installed, can reach the wall socket. Do not use extension cables for this connection. Install a tape to hold the installation tools. The appliance must be connected to the net by cable H05RN -F oil-resistant (included). The product data plate shows power and features required for the connection. The professional installer should verify that the installation environment is responding to current regulations in the Country of use of the equipment:

- A cable H05RN -F 3x1, 5 mm² section with suitable plug type (included);
- Line switch / sectioner and suitable socket type;
- Thermal unfaster and circuit breaker with sensitivity characteristics commensurate with the escape current of the heating elements. These components must be installed on user care and responsibility, close to the point of installation of the equipment.

The appliance must be connected to ground through an efficient safe system. Perform accurate both visual and instrumental controls of the conditions and characteristics of the ground plan, restoring if necessary.

-F1 and F11 have cable H05RN-F section 3x1,5 mmq oil resistant and homologated schuko plug 220/230V.

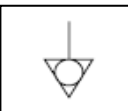

The appliance must be connected to an equipotential system whose effectiveness must be verified in accordance with the regulations in force. This connection must be made between different devices using the appropriate terminal which is marked with the symbol in the figure. The equipment must be connected to the ground line of the power grid. The bonding conductor shall have a minimum cross section of 2.5 mm². The equipotential terminal is located on the back of the oven.

FIRST IGNITION

Clean up the inner side of the oven with a humid cloth and dry well. Read the section OVEN CLEANING.

Before the first use, let the equipment to work empty at least for 30 minutes in order to eliminate the smell of "new" and a small smoke which are caused by the first ignition of the resistances. During this operation air the room.

OVEN FUNCTIONING

Once connected the plug to the electrical socket and verified that the installed electrical power is sufficient to feed the oven ever with other eventual equipments, turn on the oven, using the button on the control panel and set up the thermostat on the wished temperature, in case of pizza the temperature is 320°C, that means near the maximum. After approximately 20 minutes of preheating, carried out with closed door, the appliance will have reached the right temperature for pizza baking. To introduce or move the pizza on the refractory stones plan, it is suggested to use adapted shovels, dusted with little of flour, before being used. Once the pizza has been moved, remember to take out the shovel.

In case of baking frozen ready pizzas, keep them outside the freezer to environment temperature for approximately 10/15 minutes, before proceeding to the baking operations, as above specified. Every 4/5 minutes this appliance will bake fragrant and tasty pizzas, excellent as those of the best pizzerias. IMPORTANT! Not let fall down part of the pizza flavorings that is going to be baked (oil, tomato, cheese, etc) on the refractory stone as it will absorb the liquid part of these ingredients. The condiments must be prepared in a way to remain on the pizza, without falling on the stone.

It is also important to remember that the main characteristic of the baking plan of our oven is constituted by their refractory stone, which components have been planned by EffeUno; the refractory stone absorb sweetly the heat, than yields it in a uniform way, absorbing the humidity of the dough. Only in this way, with the direct contact to the refractory stone, it is possible to obtain the pizza baking in 4/5 minutes and in the same time to maintain unchanged the nutritive values

Our pizza oven can be used for the baking of other foods (fish, vegetables, chicken, etc). In this case, it is absolutely necessary to use appropriate oven containers, in aluminum paper, easy available by whichever store and supermarket but only after having checked that they are suitable for food and resistant to high temperatures heating.

Do not put flour on refractory stones plan as it could emanate a lot of smoke and produce fire

OVENS MOD. F1 AND F11

Ovens F1 and F11 were studied to cook food in narrow spaces.

Both of models have separate thermostats to control each heating elements separately.

Oven mod. F11 has 2 separate chambers, the upper one, letter "A" and the lower one, letter "B". Both have separate control of temperature, so



INSTRUCTIONS MANUAL

Professional Electric Oven mod.

F1 - F1C - F11 - F11C

Release
01 - 2019



each thermostat controls a heating element. F11 has a general switch for each cooking chamber while F1 has 1 general switch. Thermostats on the oven F1 and F111 reach a 350°C temperature. For proper cooking of the food we suggest you never exceed a 320 °C temperature, in order to avoid burning food or leaving them uncooked inside . Room lights are always on while the oven is operating. The F11 oven model is reproduced below with related control panel and associated control tools. Upper chamber is letter "A" while bottom chamber is the "B". For F1 correct work, just consider only the "B" chamber, as it can be consider a half of an F11.

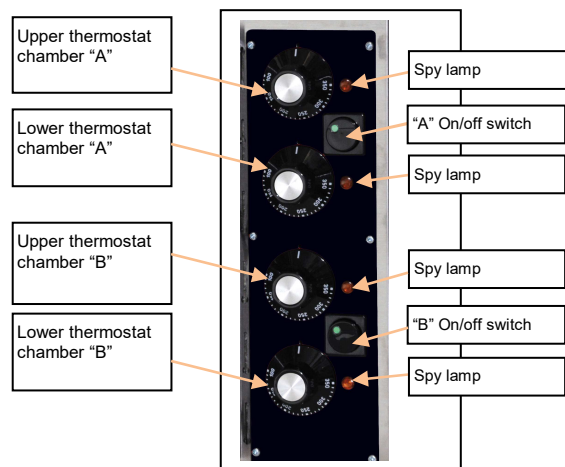
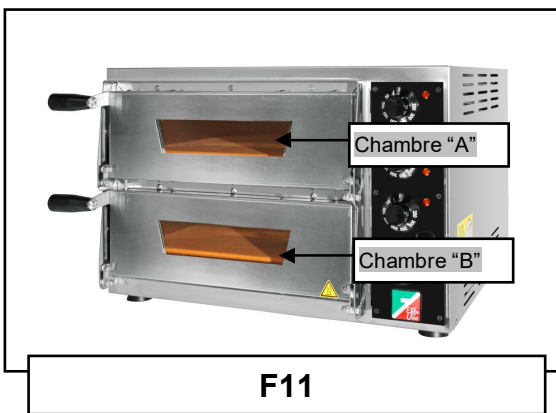
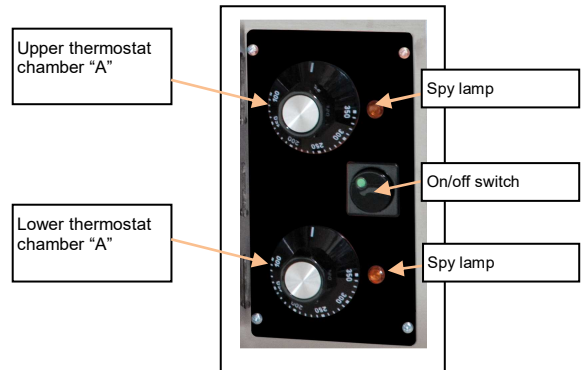
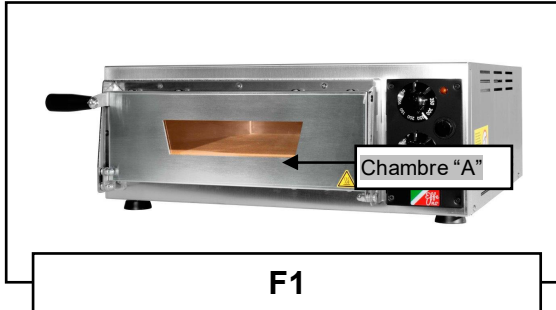

OVEN CLEANING

If the oven is dirty inside, the baking times can be longer than usual. A frequent cleaning avoids formations of smoke and bad smells during the baking. Before whichever cleaning always remove the plug from the electrical socket. **Never dip the appliance in water; do not wash it under a water jet, it can compromise the electrical safety of the oven!!!!** For the cleaning of the external surface always use a humid sponge. Avoid to use abrading products that would damage the varnish. Pay attention that water or liquid soap don't penetrate inside the oven embrasures. For the cleaning of the internal side of the oven never use corrodng products (spray detergents) , do not scrape the walls with point shaped or cutting objects. Never clean the resistances. IMPORTANT: FOR YOUR SAFETY THE CLEANING MUST BE DONE ALWAYS WITH COLD OVEN!

PACKING AND DISPOSAL

All the materials used for packing are compatible with the environment and can be recycled. Correctly dispose of any refuse, such as the packing materials, by placing them in the proper waste bins, so to avoid any environmental pollution. PLEASE KEEP OVEN PACKING BOX. Please give your contribution to the environment conservation. The appliances that are no more used or are not usable are not refusals worthless. Through the ecological disposal, various materials employed in the production of your equipment can be recovered. Take information about actual disposal possibility by your specialized retailer, or by your district Administration. Before disposing your equipment, cut the power supply cable and let it be unsuitable. BEFORE CUTTING THE CABLE REMOVE THE PLUG FROM THE CURRENT.

GUARANTEE CONDITIONS

The appliance is covered by trading GUARANTEE for a period of one year from the purchase date. The validity of the GUARANTEE always must be proven from a fiscal document (fiscal buying document, transport documents or invoice) and covers exclusively all the components which result to be defective from the origin caused by fabrication defects. The manufacturing defects that are manifested within six months from the delivery, excluding contrary proof or incompatibility with the nature of the good, are presumed already existing at the date of the delivery. Therefore there are excluded all the parts that have got accidental damages or that they are subject to usury, defects deriving from not professional use of the appliance, the cleaning and repair of the refractory stone (the refractory stone, if used, is never considered under guarantee) negligence in using or in the maintenance, transport damages and all those damages not directly imputable to EffeUno. The appliance must be repaired exclusively from staff authorized by EffeUno; the eventual reparation made by non-authorized staff will decay the GUARANTEE. The repairs have to be carried out by one of the Assistance Technical Centers authorized by EffeUno. In case a defect of conformity in the EffeUno product has to be manifested after the sixth month from the delivery, the final user that has the right to the guarantee to the senses of the above mentioned laws will have to address to the retailer or, in alternative, to a Assistance Technical Centers authorized by EffeUno enclosing the following documentation:

- Fiscal buying document, transport document or invoice.
- Proof that the damage can be considered a defect that the law classifies in the category " defects of conformity " .
- Proof that such defect is imputable to EffeUno.

In lack of what above mentioned, the restoration of the functionalities it will be executed under payment.



INSTRUCTIONS MANUAL

Professional Electric Oven mod.

F1 - F1C - F11 - F11C

Release
01 - 2019



OVENS TECHNICAL SPECIFICATIONS

	Working Tension	Electrical Power	Wire Length	External Dimensions (mm)		Inner Dimensions (mm)		Weight
				BxLxH	BxLxH	BxLxH	BxLxH	
F1	220V-230V ~ 50/60Hz	1750W schuko plug	1,5 m sect. 1,5 mmq	520 x 580 x 210	350 x 410 x 80	15Kg		
F1C		1750W schuko plug	1,5 m sect. 1,5 mmq	520 x 580 x 210	350 x 410 x 80	15Kg		
F11		3500W schuko plug	1,5 m sect. 1,5 mmq	520 x 580 x 350	350 x 410 x 80	30Kg		
F11C		3500W schuko plug	1,5 m sect. 1,5 mmq	520 x 580 x 350	350 x 410 x 80	30Kg		
F11 2017UK		3000W 13A UK plug	1,5 m sect. 1,5 mmq	520 x 580 x 350	350 x 410 x 80	30Kg		

The manufacturer EffeUno S.r.l. reserves the right to make ELECTRICAL-TECHNICAL-ESTHETICAL changes on this device and / or replace parts without prior notice, if considered more appropriate, in order to offer always a reliable, better, long-term and with advanced technology product.

EC DECLARATION OF CONFORMITY



Messrs

EFFEUNO S.r.l. sole-associate
Via Mozart, 43
35011 Campodarsego – (Padova) Italy

Declare under their own responsibility that:

Name of product: Pizza Oven
Product code: F1-F1C-F11-F11C

Comply with Safety Standards as foreseen by International norms and European directives:

IEC 60335-2-36:2017
IEC 60335-1:2010 + A1:2013 + A2:2016

EN 60335-2-36:2002 + A1:2004 + A2:2008 + A11:2012
EN 60335-1:2012 + A11:2014 + A12:2017 + A13:2017
EN 62233:2008

Padova, 01-01-2019

(place and date)

(name and signature of authorized personnel)